

Idler wheels

Part. 311 Split idler wheel 21 teeth (for chains series 812-815-820-831)

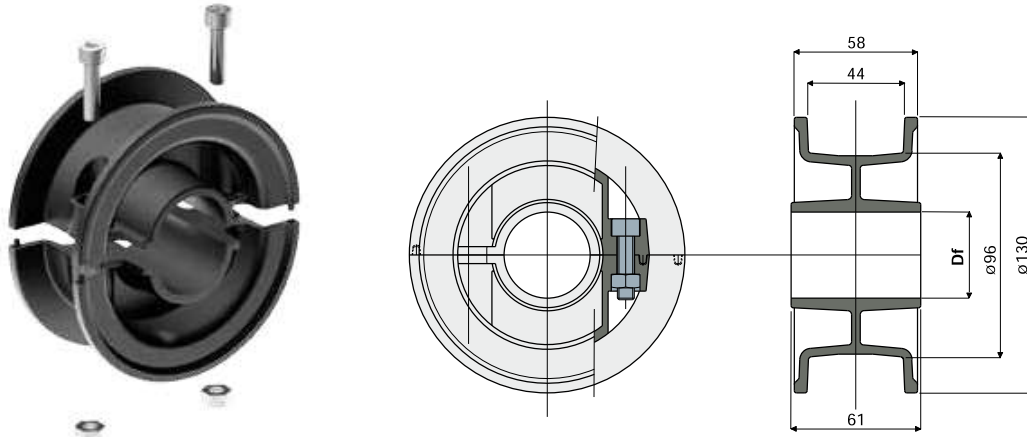

Df Bore for pin of (mm)	Code
25	311 / 82841
30	311 / 82842
35	311 / 82843
40	311 / 82844

MATERIALS: Wheel made of polyamide black colour; bolts and nuts made of stainless steel AISI 304.

FEATURES: Supplied assembled. To be used for chain return in the series 812, 815, 820, 831.

BOX QUANTITY: 12 pieces.

ON REQUEST:

- Wheels: With special bores, other colours.
- Box Quantity: According to your request.

Part. 285 Split idler wheel 25 teeth (for chains series 812-815-820-831)

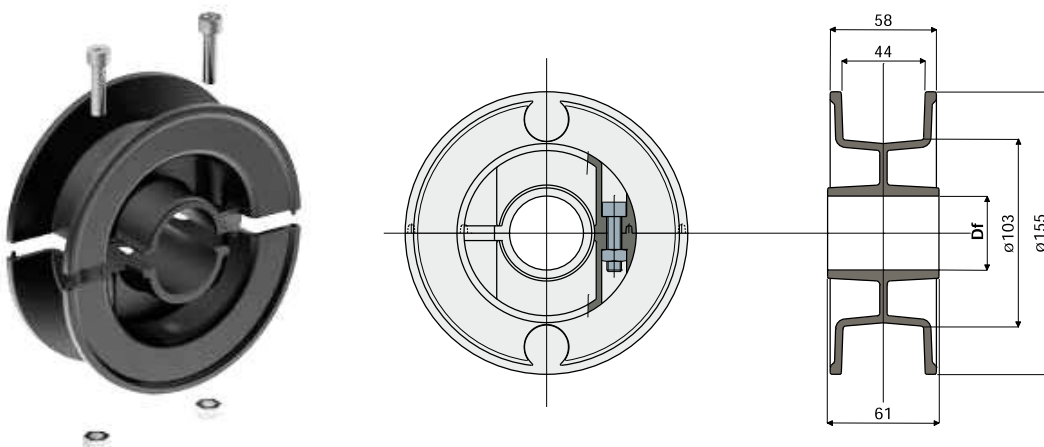

Df Bore for pin of (mm)	Code
25	285 / 82526
30	285 / 82528
35	285 / 82529
40	285 / 82530

MATERIALS: Wheel made of polyamide black colour; bolt and nuts made of stainless steel AISI 304.

FEATURES: Supplied assembled. To be used for chains Series 812, 815, 820, 831.

BOX QUANTITY: 12 pieces.

ON REQUEST:

- Wheels: With special bores, other colours, with customer brand.
- Box Quantity: According to your request.

Idler wheels

Split idler wheel 10 teeth

(for chains series 879 Tab, 880 Tab and 881 Tab)

Part. **310**

Df Bore for pin of (mm)	Code
20	310 / 82827
25	310 / 82828
30	310 / 82829
35	310 / 82830
40	310 / 82831

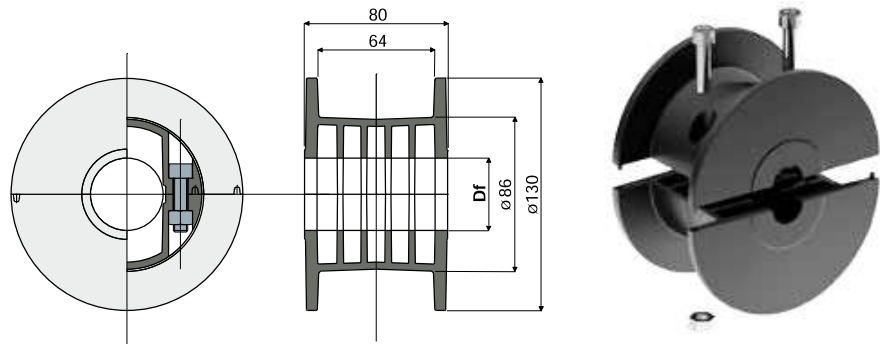

MATERIALS: Wheel made of polyamide black colour; bolts and nuts made of stainless steel AISI 304.

FEATURES: Supplied assembled. To be used for chain return in series 879 Tab, 880 Tab and 881 Tab.

BOX QUANTITY: 12 pieces.

ON REQUEST:

- Wheels: With special bores, other colours.
- Box Quantity: According to your request.

Idler wheel for chain return

Part. **268**

Df Bore for pin of (mm)	Code
20	268 / 82040

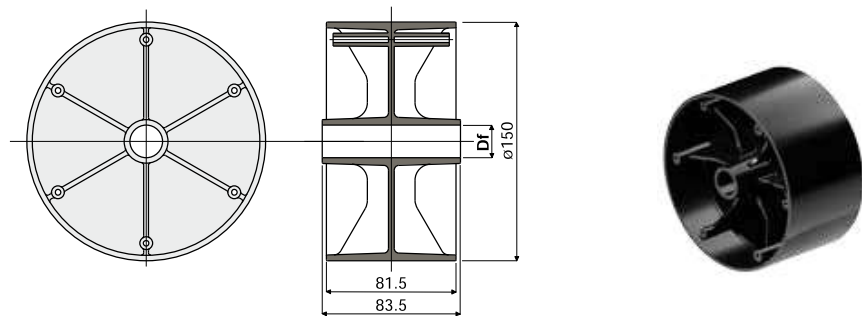

MATERIALS: Wheel in polyamide black colour.

FEATURES: To be assembled in the chain return near to the sprocket.

BOX QUANTITY: 12 pieces.

ON REQUEST:

- Wheels: Other bore sizes, materials and colours.
- Box Quantity: According to your request.

Flange for chain guide

(for idler wheel Part. 268)

Part. **269**

Df Bore for pin of (mm)	Code
20	269 / 82041

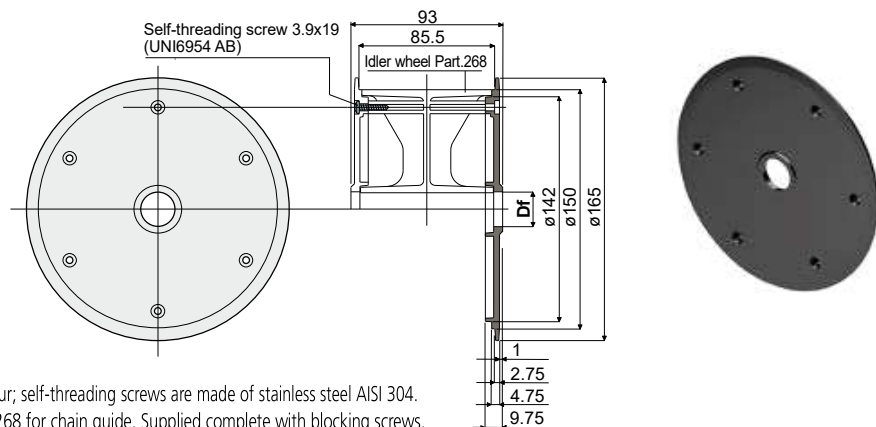

MATERIALS: Flange is made of polyamide black colour; self-threading screws are made of stainless steel AISI 304.

FEATURES: To be assembled to our idler wheel Part.268 for chain guide. Supplied complete with blocking screws.

BOX QUANTITY: 24 pieces.

ON REQUEST:

- Flanges: Other bore sizes, materials and colours.
- Box Quantity: According to your request.